

NORRIS CAFEMASTER AWC

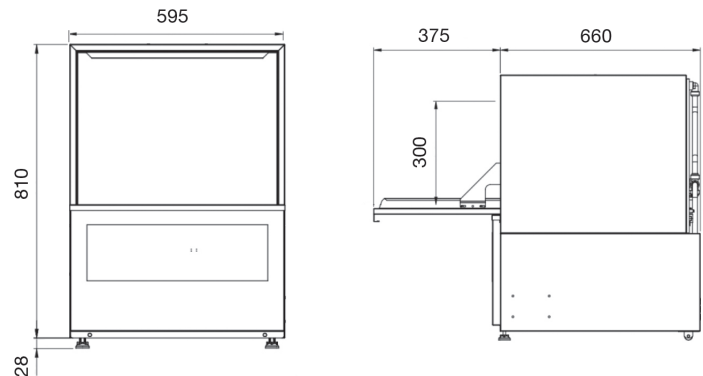

The Cafemaster Advanced Wash Control model is a compact underbench dishwasher with a large focus on environmental sustainability. This proven hardworking machine will produce a sparkling wash time after time.

FEATURES

- **Warranty:** 2 years parts and labour, 5 years on the cabinet & control board (see p.26 for conditions & extended warranty offer)
- Compact underbench dishwasher suited for cafes and small restaurants
- Cleans up to 600 plates per hour
- 1, 2 & 5 minute wash cycle options
- Automatic detergent and rinse aid injection for consistent results and controlled consumption
- Rapid boiler recovery for a faster turn around
- Fit standard with a drain pump allowing easy installation
- Rinse temperature accurately controlled by the thermostop function
- Rear rollers for easy inspection and cleaning
- Double skinned door reducing heat and noise pollution
- High grade stainless steel welded cabinet, wash arms and scrap trays for durability
- Australian made

INCLUSIONS

- 1 x Flat rack insert 500mm x 500mm
- 1 x Plate rack insert 500mm x 500mm
- 1 x Cutlery container
- 1 x Water connection hose
- 2 x Adjustable & 2 x Roller feet
- 2 x Chemical weights & filters
- 1 x Operating manual

TECHNICAL DATA

Height

Cabinet	810 mm
Cabinet inc. legs	838 mm
Usable Wash	300 mm

Width

Cabinet	595 mm
---------	--------

Depth

Cabinet	660 mm
With door open	1035 mm

Capacities

Loads/Hour	up to 30*
Water per Cycle	3L
Wash Pump	370W
Wash Tank Litres	18
Boiler Tank Litres	6
Element (wash)	500W
Element (boiler)	3000W
Detergent Injection	yes
Rinse Aid Injection	yes

Temperatures

Wash Degrees C	62 °C
Rinse Degrees C	85 °C

Plumbing

Drain	Pump out
Water	½" BSP (hot)

Electrical

Volts/Hz	240V AC/50Hz
Max. Amp. load	15amps
Note: this machine has load shedding capability	

* Subject to incoming water temperature